

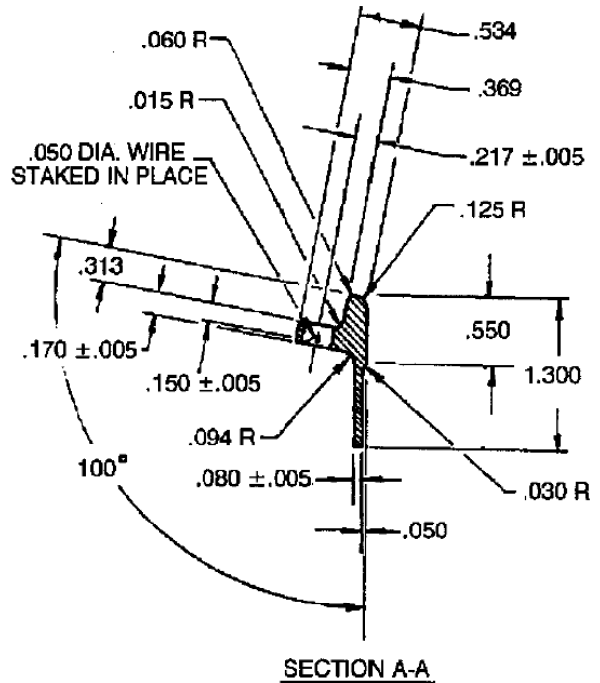

Exceeding Your Expectations

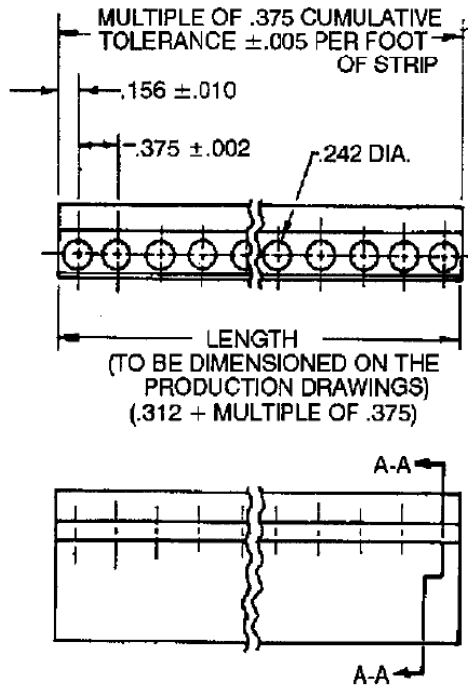

Material: Wire: 0.050 diameter 316 stainless steel wire, Condition B, spring temper
 Receptacle: 7075T76511 ALUMINUM ALLOY PER QQ-A-200/15

Finish: Wire: None
 Strip: Aluminum coat, ion vapor deposition, in accordance with MIL-DTL-83488 Type II, Class 3, except ends may be chemically surface treated in accordance with MIL-C-5541.

Quality Conformance Inspection: MIL-F-25173

DIMENSIONS IN INCHES: TOLERANCES UNLESS OTHERWISE SPECIFIED: X.XX ± 0.03 ; X.XXX ± 0.010 ; ANGLES $\pm 0.5^\circ$
 DOCUMENT AND ITS CONTENTS ARE PROPRIETARY INFORMATION TO STROCO AND ITS AFFILIATES. USE WITHOUT AUTHORIZATION IS PROHIBITED.

CAGE NO. 19904	TITLE RECEPTACLE - TURNLOCK FASTENER, ANGLE MOUNTING STRIP	PART NUMBER S26051VD-XXX <small>XXX= Number of receptacle holes</small>
		REV A 05/08/06