



Exceeding Your Expectations

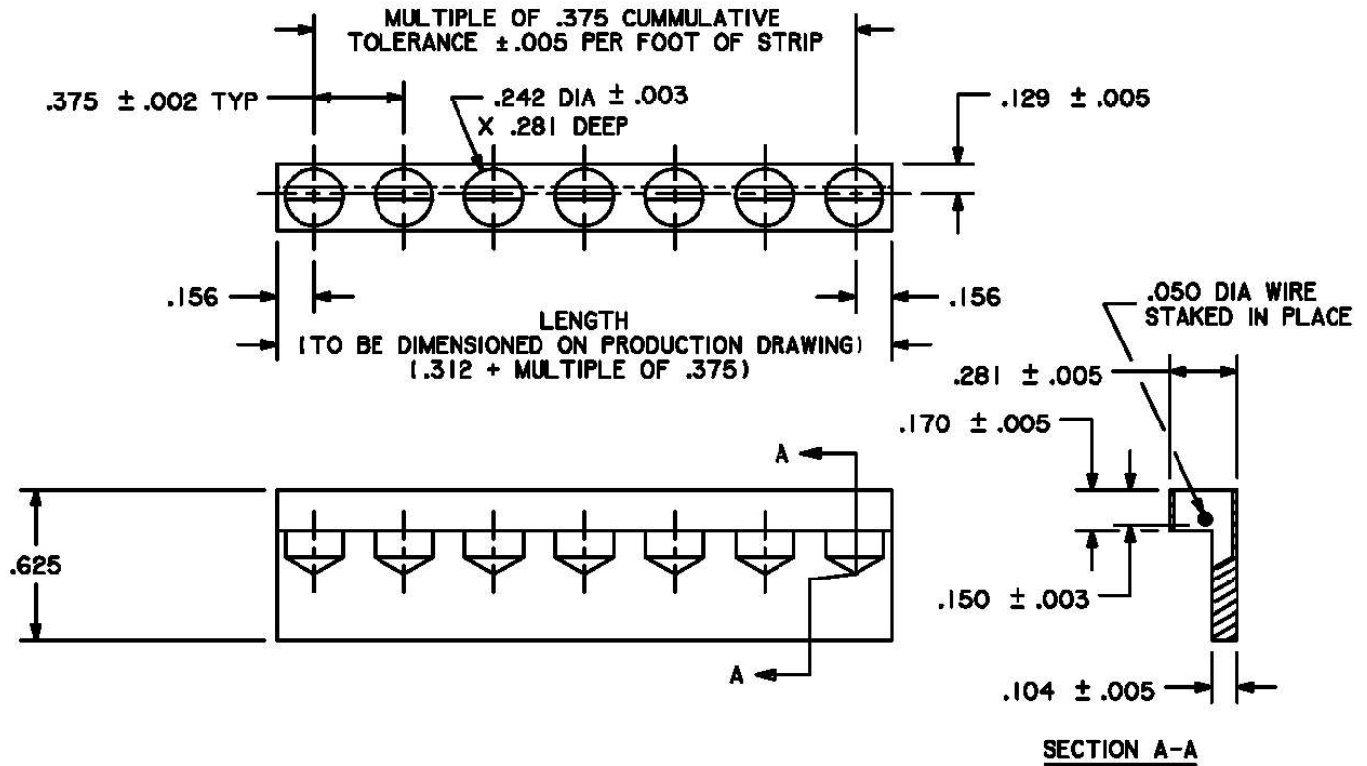

FIGURE 1

MATERIAL:

Wire: 0.050 diameter 316 stainless steel wire,
Condition B, spring temper per ASTM A 313/A 313/M
Receptacle: 6061-T6 Aluminum alloy in accordance with AMS-QQ-A-200/8

FINISH:

Wire: None
Strip: See Optional Finish Codes below:
No code = No finish
A = Alodine MIL-DTL-5541, Class 1A
IVD = Ion vapor deposition, MIL-DTL-83488, Type II, Class 3.
Ends may be conversion coated in accordance with MIL-DTL-5541, Class 1A
N = Anodize per MIL-A-8625, Type II, Class 2
NB = Black Anodize to meet requirements of MIL-A-8625, Type II, Class 2 or BACS716, Type II, Class 2. Seal in deionized water or nickel acetate.

EXAMPLE OF CALLOUT:

S2805A - XXX
└── NUMBER OF RECEPTACLE HOLES
└── FINISH
└── BASIC PART NUMBER

MARKING:

PART TO BE MARKED WITH MANUFACTURER AND PART NUMBER PER MIL STD 130

QUALITY CONFORMANCE INSPECTION:

MIL-F-25173

DIMENSIONS IN INCHES: TOLERANCES UNLESS OTHERWISE SPECIFIED: X.XX ± 0.03; X.XXX ± 0.010; ANGLES ± 0.5°
DOCUMENT AND ITS CONTENTS ARE PROPRIETARY INFORMATION TO STROCO AND ITS AFFILIATES. USE WITHOUT AUTHORIZATION IS PROHIBITED.

<p>CAGE NO. 19904</p>	<p>TITLE RECEPTACLE – TURNLOCK FASTENER, ANGLE MOUNTING STRIP</p>	<p>PART NUMBER S2805-XXX <small>XXX= Number of receptacle holes</small> REV C 10/17/2019</p>
---------------------------	--	--